



## **INDUSTRIAL PROGRESS VIEWER**

**THE EASIEST WAY TO LOOK AT THE  
PROGRESS OF YOUR PROJECT**

**Presented by Whitney Childress**



## **DESCRIPTION**

IPV is a web-based application that fully transforms a CPM schedule into a 2-D model to visually illustrate the progress and/or scenarios for a turnaround/capital project. Additionally, IPV's comparison view allows end-users to instantaneously view the CPM's updated target(s), actual and deltas of the schedule eliminating wasted time sifting through pages and pages of CPM reports.

If traditional reporting is still required, IPV's capability to provide simple, easy to view reports that satisfy all organizational requirements is also available. With IPV's web based features and integration with your firm's enterprise/organization structures, IPV will allow the appropriate end-users to view status reports for all current, past, and future turnarounds/projects in real time as they become available.

It is time to let IPV revolutionize the way your firm analyzes the turnaround/capital process.

# BASELINE SCREENSHOT / BEGINNING (ALL)

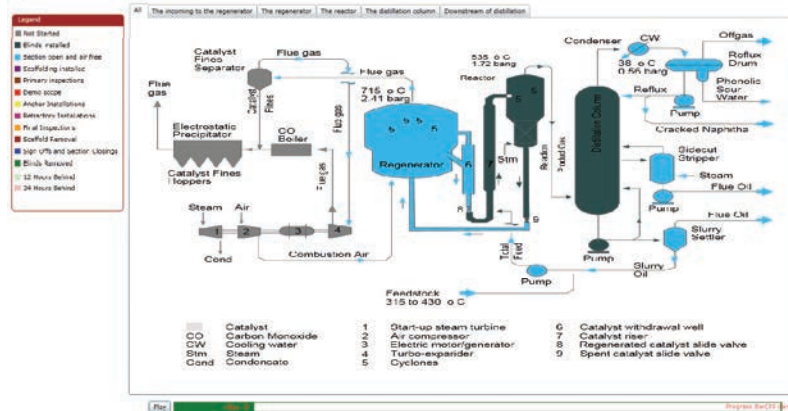

3

# BASELINE SCREENSHOT / BEGINNING (ALL)

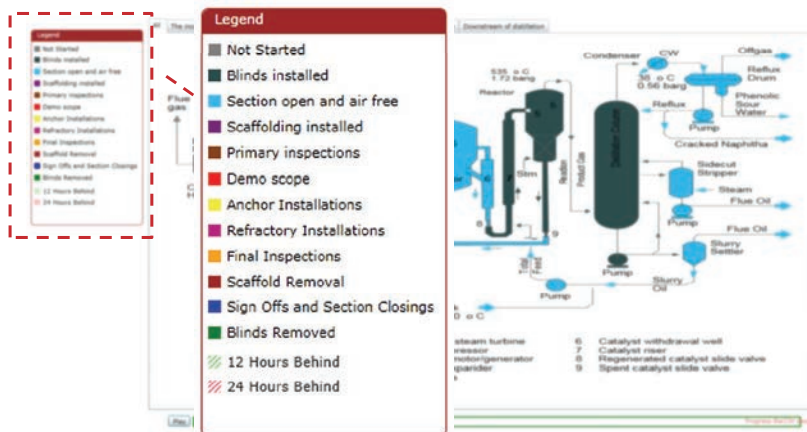

4

# BASELINE SCREENSHOT / BEGINNING (SPECIFIC EQUIPMENT)

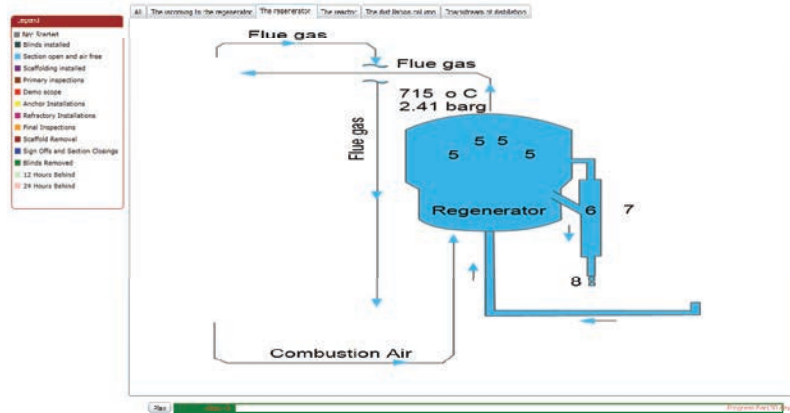

5

# BASELINE SCREENSHOT / MIDWAY (ALL)

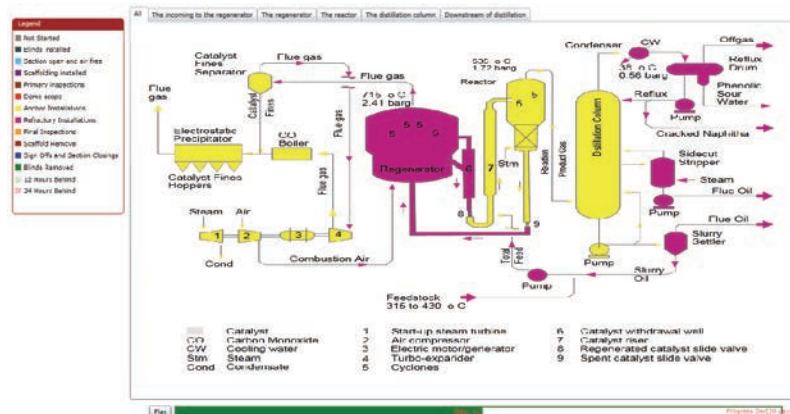

6

# BASELINE SCREENSHOT / 3 DAYS BEFORE END (ALL)

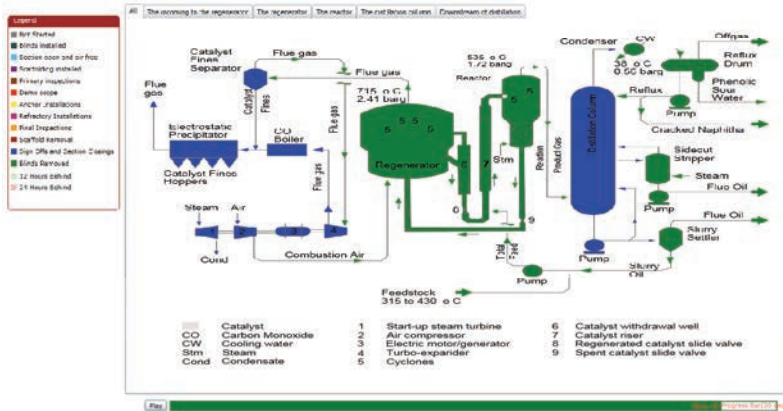

7

# BASELINE SCREENSHOT / 3 DAYS BEFORE END (SPECIFIC EQUIPMENT)

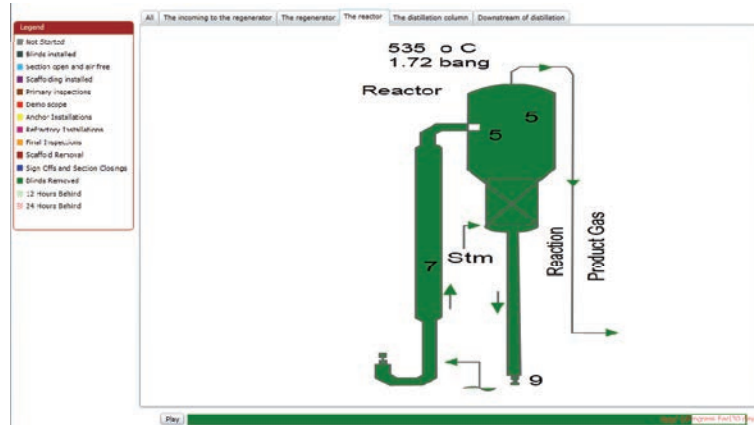

8

# COMPARATIVE SCREENSHOT / BEGINNING (ALL)

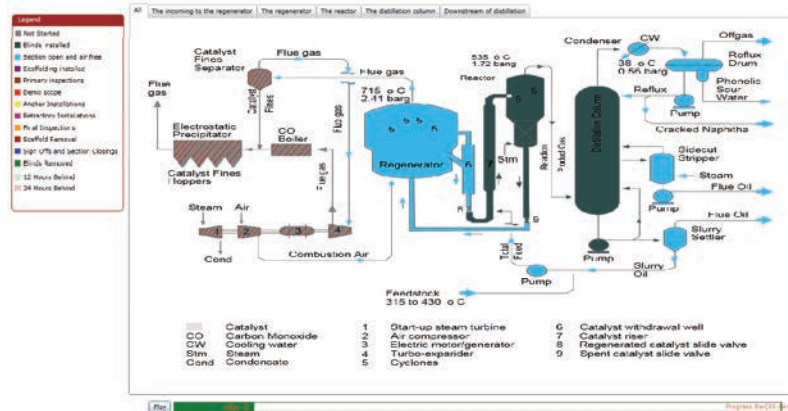

9

# COMPARATIVE SCREENSHOT / BEGINNING (SPECIFIC EQUIPMENT)

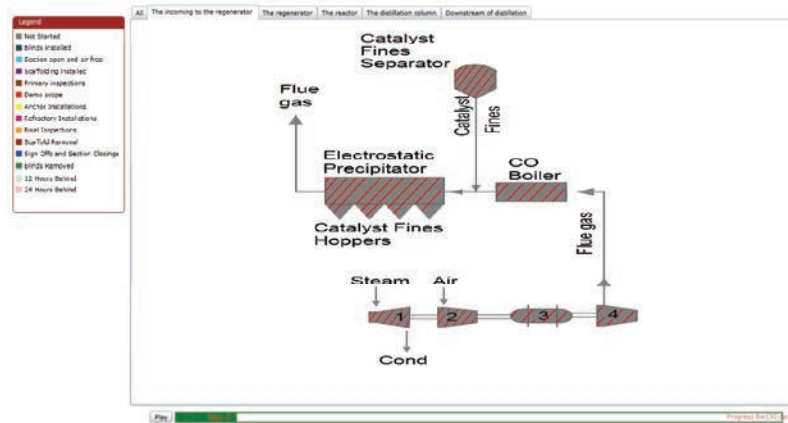

10

# COMPARATIVE SCREENSHOT / 3 DAYS BEFORE END (ALL)

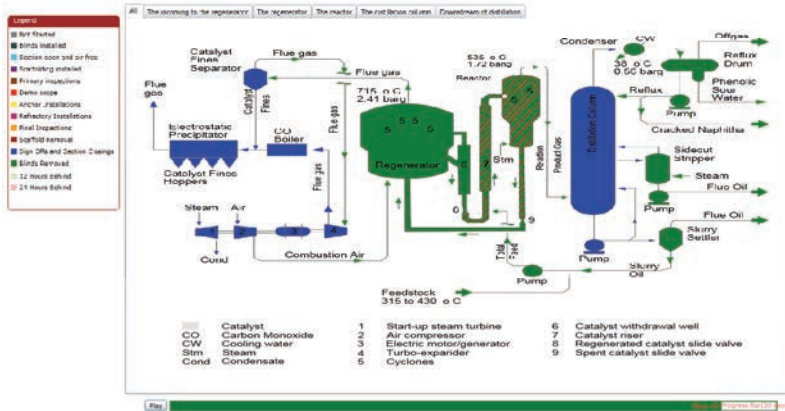

# COMPARATIVE SCREENSHOT / 3 DAYS BEFORE END (SPECIFIC EQUIPMENT)

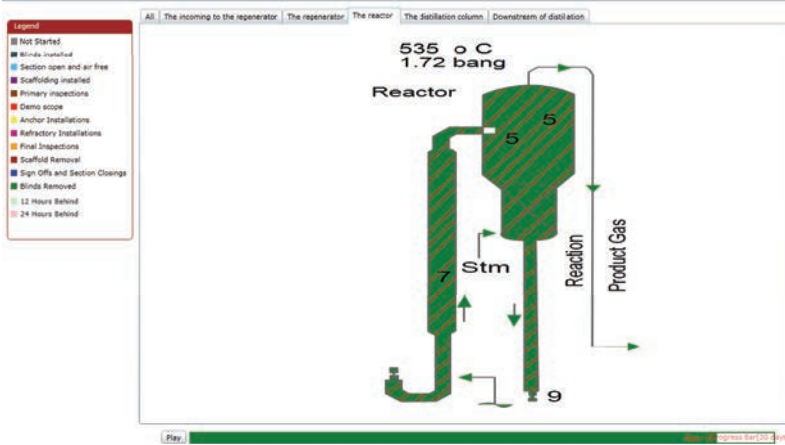

# STANDARD IPV VERSION / BASELINE - ALL

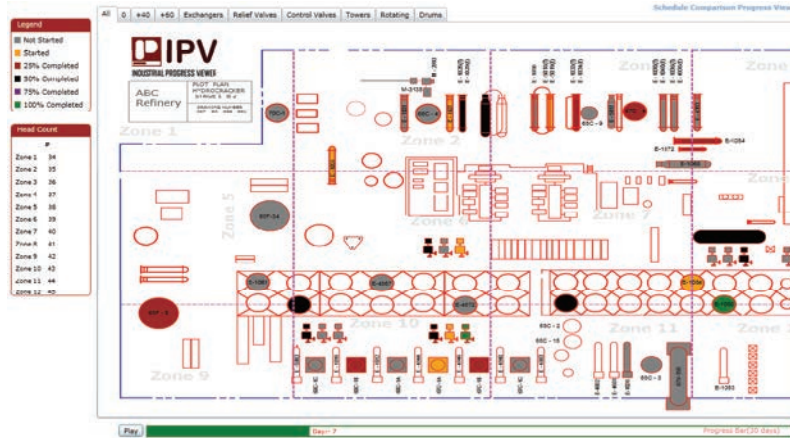

13

# STANDARD IPV VERSION / BASELINE - EXCHANGERS

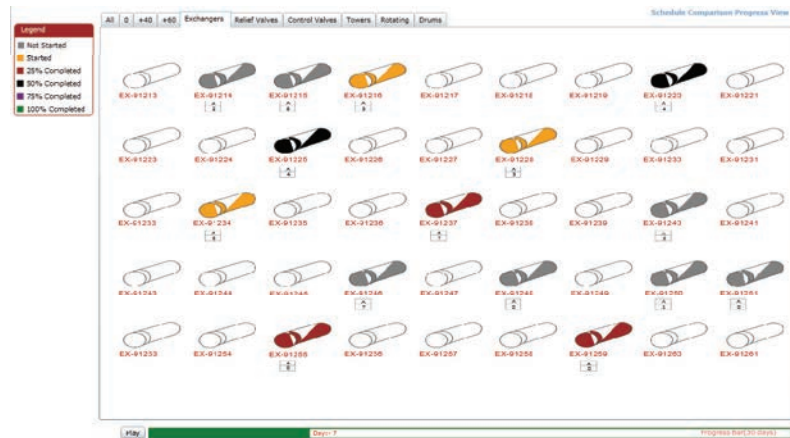

14

## **CONCLUSION**

Industrial Progress Viewer\* is an application which allows users to take control of their CPM schedule. IPV transfers reports into a simple 2-D model, allowing a more visual picture of the Turnaround in real time. Let IPV be the preferred tool for your next Turnaround!

**Whitney Childress**

[whitney.childress@itc.jobs](mailto:whitney.childress@itc.jobs)

[www.turnaroundcontrols.com](http://www.turnaroundcontrols.com)