

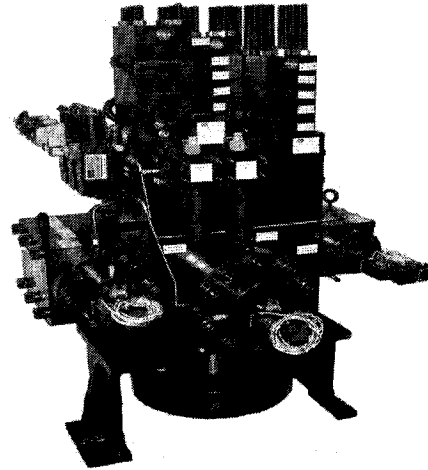

Water Hydraulics, Inc.

# High Pressure Water Decoking Valves

## Long Life Ease of Maintenance



May 2006

**Coking.com**  
BOTTOM OF THE BARREL



Water Hydraulics, Inc

# Typical Sequence of Operations

*Typical Schematic  
Pump and Cutting Water Control*

- Separate Functions for Pump Bypass
- Prefill
- Cutting

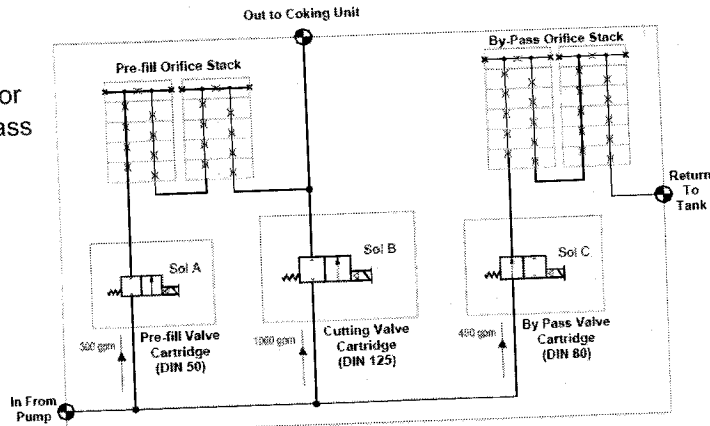

May 2006

**Coking.com**  
BOTTOM OF THE BARREL



Water Hydraulics, Inc.

## Cutting Valve Cartridges

- True Cartridge Design
- Heat Treated Stainless Steel Internals
- Low Low Pressure Drop

### Quad-S™ Cartridge (Stainless Steel, Soft Shift)

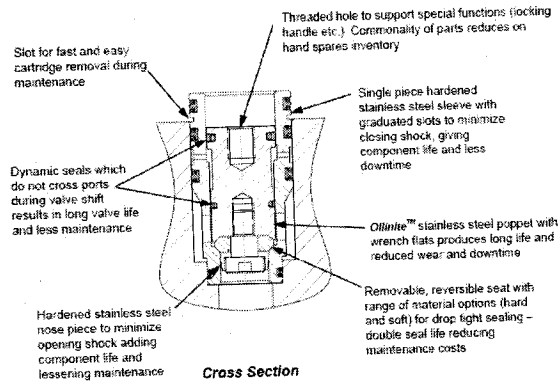

May 2006

**Coking.com**  
BOTTOM OF THE BARREL

3



Water Hydraulics, Inc.

## Thank You

John Fisher  
330.332.4444  
BOC Water Hydraulics Inc.  
12024 Salem Warren Road  
P.O. Box 1028  
Salem, Ohio 44460

[www.BocWaterHydraulics.com](http://www.BocWaterHydraulics.com)

May 2006

**Coking.com**  
BOTTOM OF THE BARREL

4