

New Inventions for Extending The Service Life of Coke Drums

Mahmod Samman, Ph.D., P.E.

Houston Engineering Solutions, LLC

(+1) 832-512-0109

mms@hes.us.com

RefComm

Galveston 2016

Houston
ENGINEERING SOLUTIONS

REFCOMM[®]
GALVESTON
MAY 2-6 2016

Overview

Three issued and pending HES patents in last two years aimed at mitigating or minimizing classic coke drum failures:

- Non-welded skirt attachment
- Non-bolted skirt anchors
- Fatigue-resistant shell

Non-welded skirt attachment

Skirt Attachment Cracking

API 1996 Survey

Skirt Cracking Results

Description	Location	Percent Cracking
Cracking at Weld	A, B&C	56%
Cracking into Shell	A	43%
Cracking from Skirt OD	B	63%
Cracking From Skirt ID	C	26%
Cracking at Slots / Keyholes	D	76%
Total Cracking in Skirts	A, B, C, & D	78%

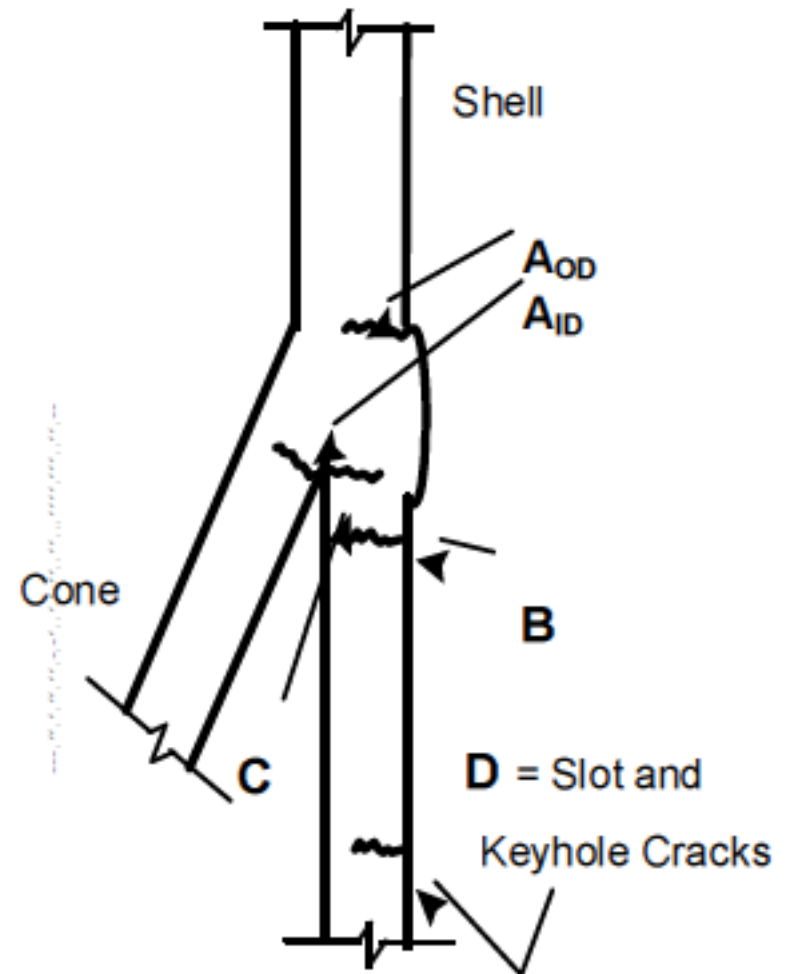

HES Tongue-and-Groove Skirt

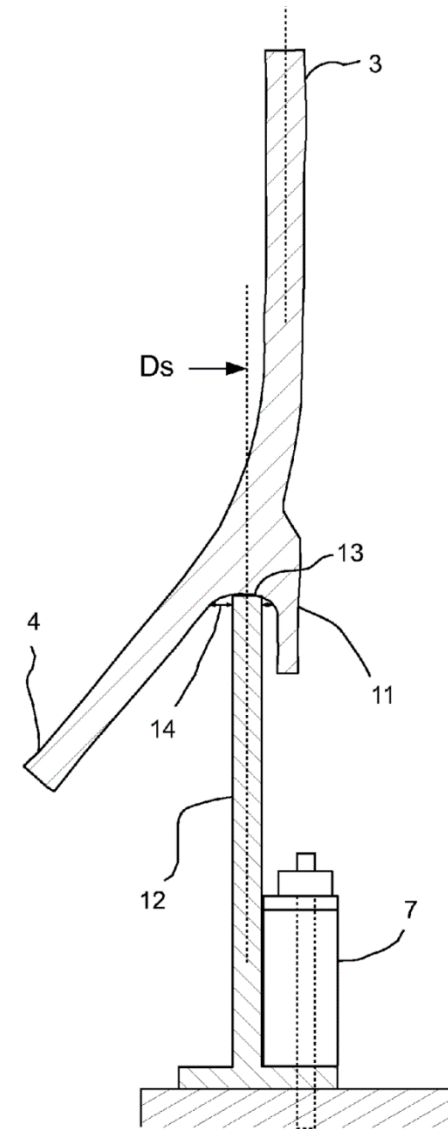
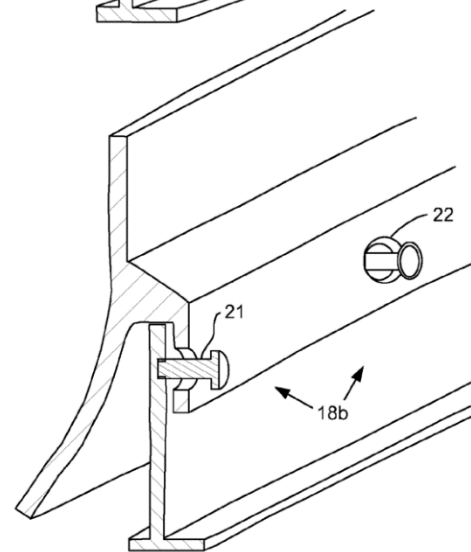
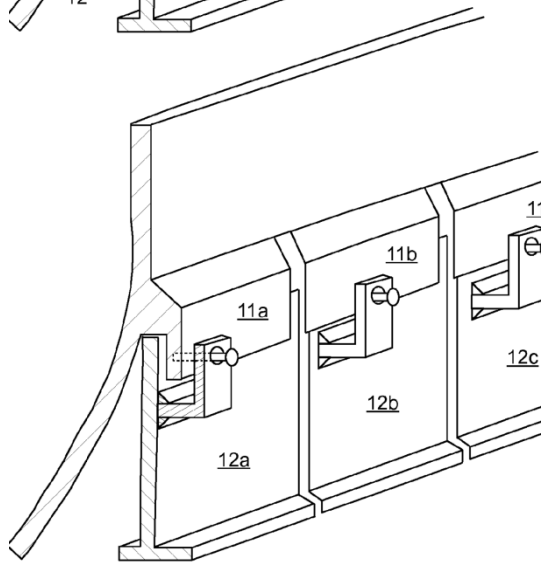
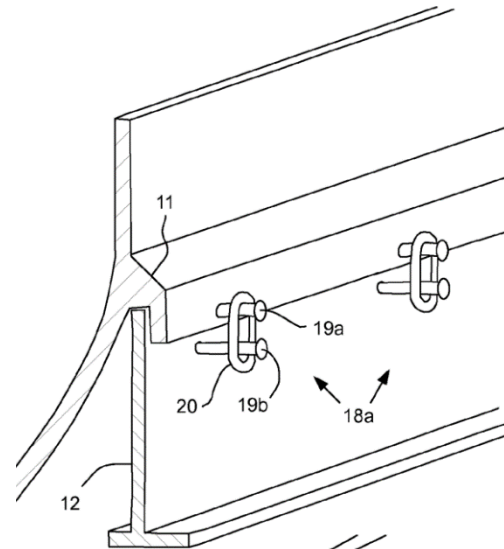
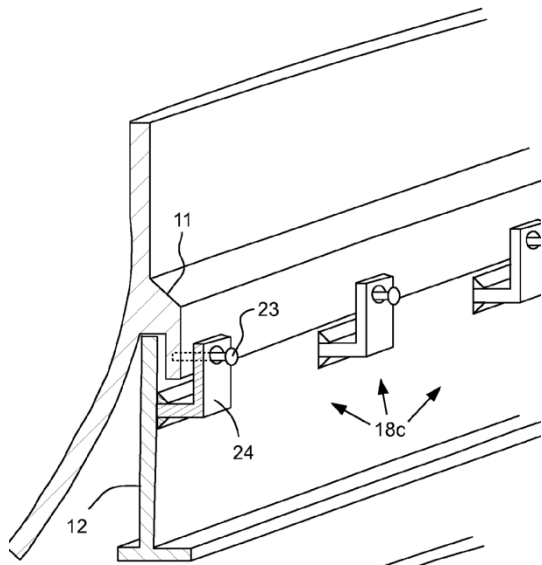

Status

- Precedents:
 - Sliding skirt 2002 (24+ drums in operation)
 - Retrofit 2011 - in operation
 - Undocumented set 30+ years in operation
- Being implemented

Non-bolted skirt anchors

Skirt Bolt failures

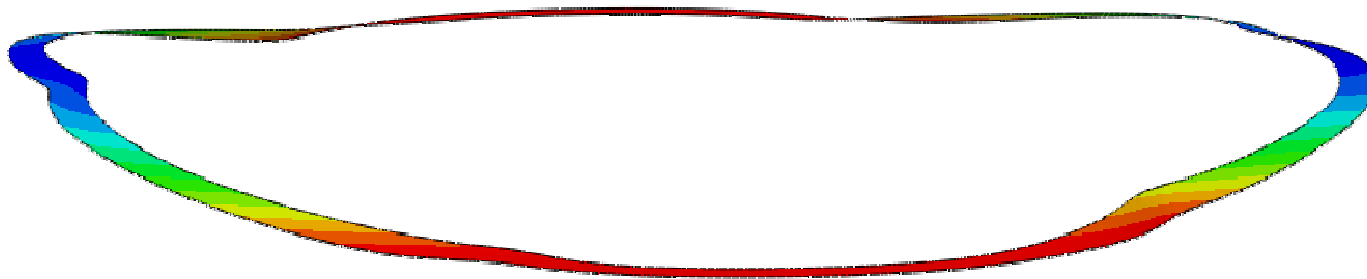
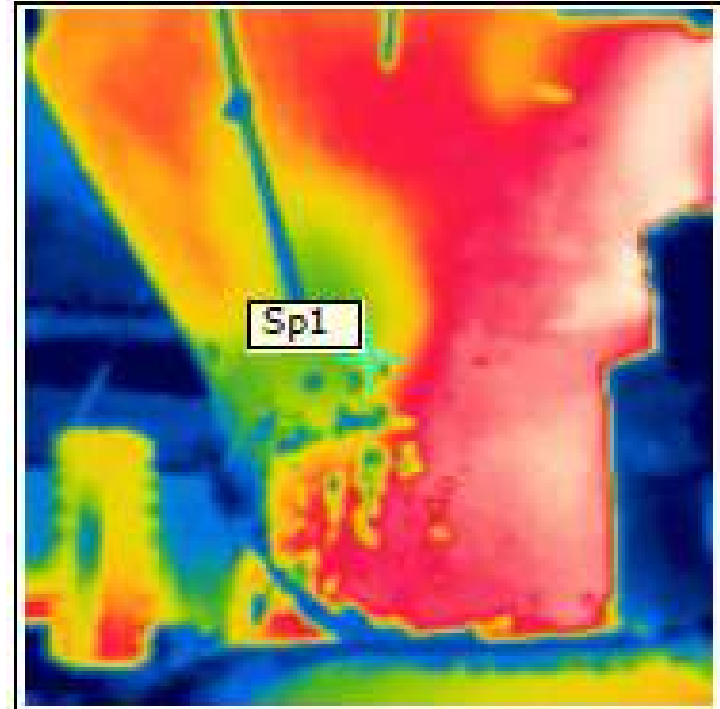
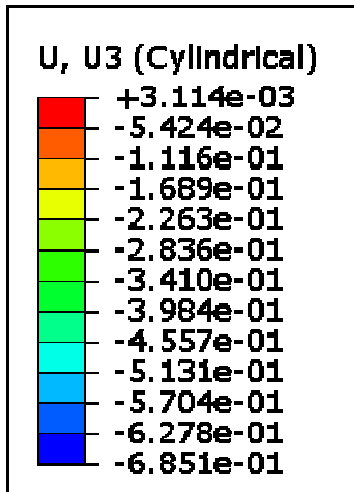

HES Clearance-Restraint Anchors

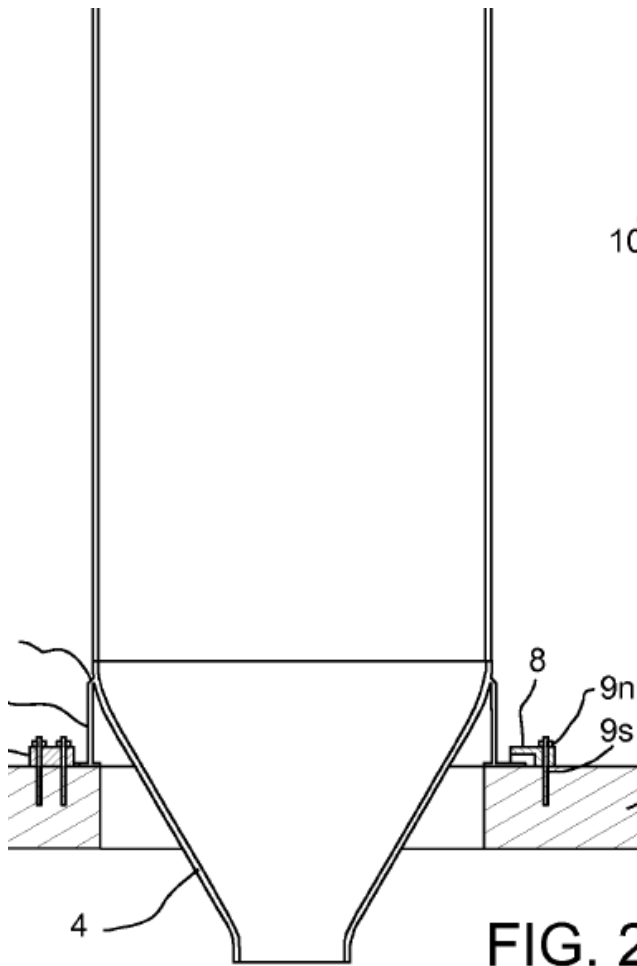

FIG. 2A

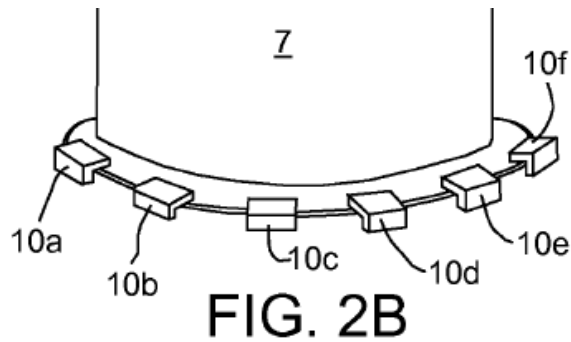

FIG. 2B

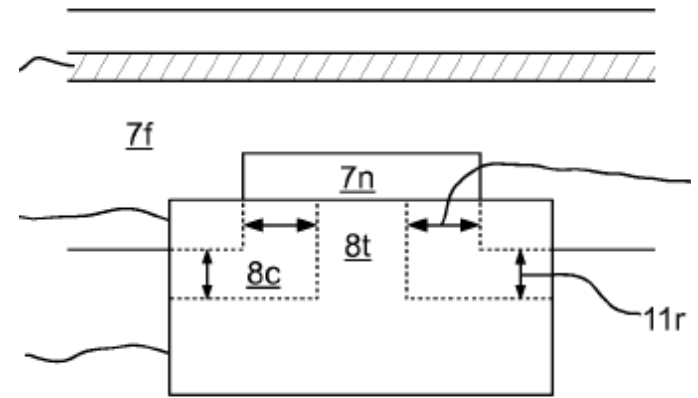
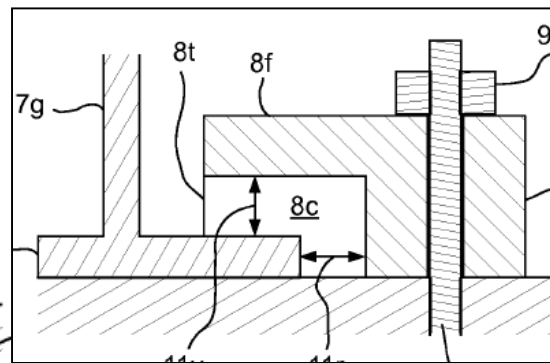
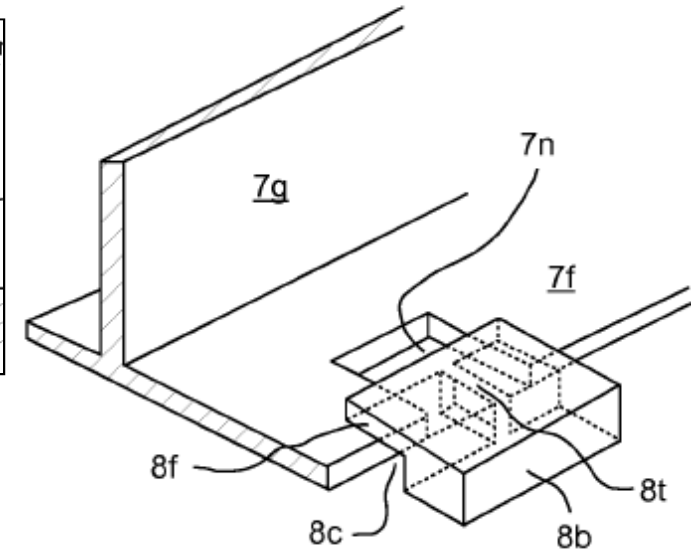

FIG. 3B



Status

- Not aware of any precedents
- Being implemented

Fatigue-resistant shell

Seam Bulging

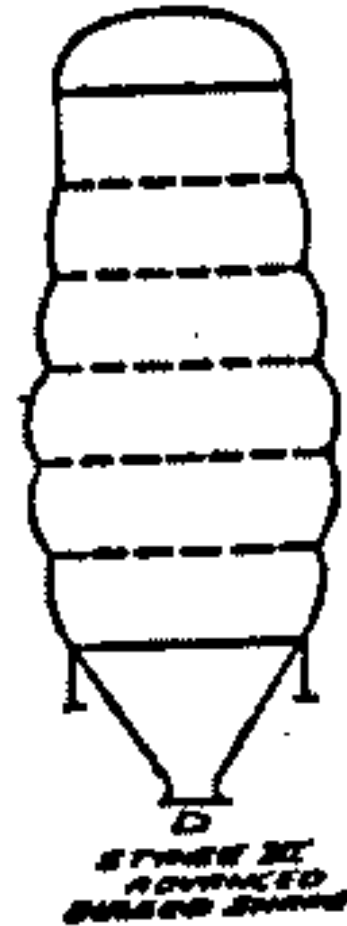
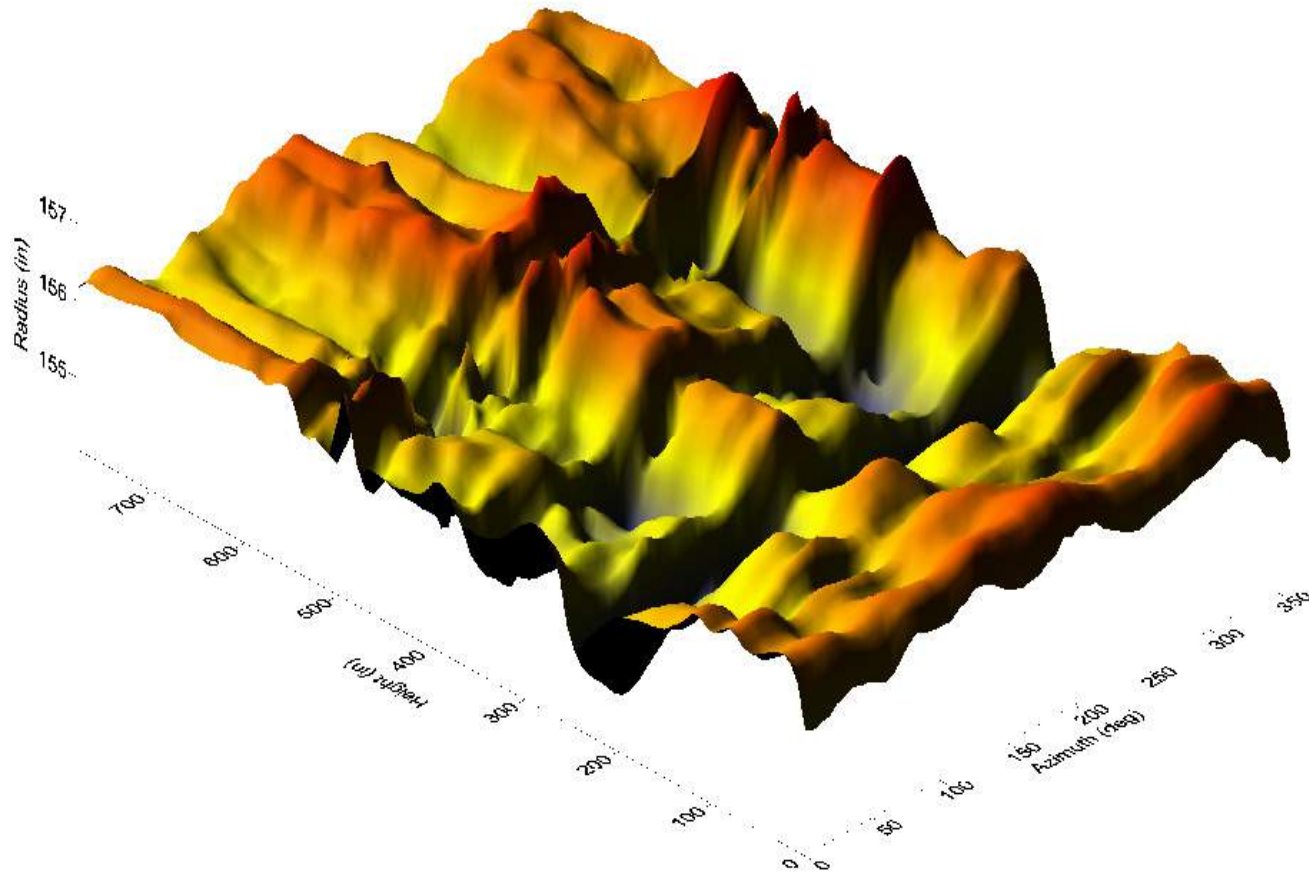

Weil & Rapasky 1958

HES Staggered-Seam Shell

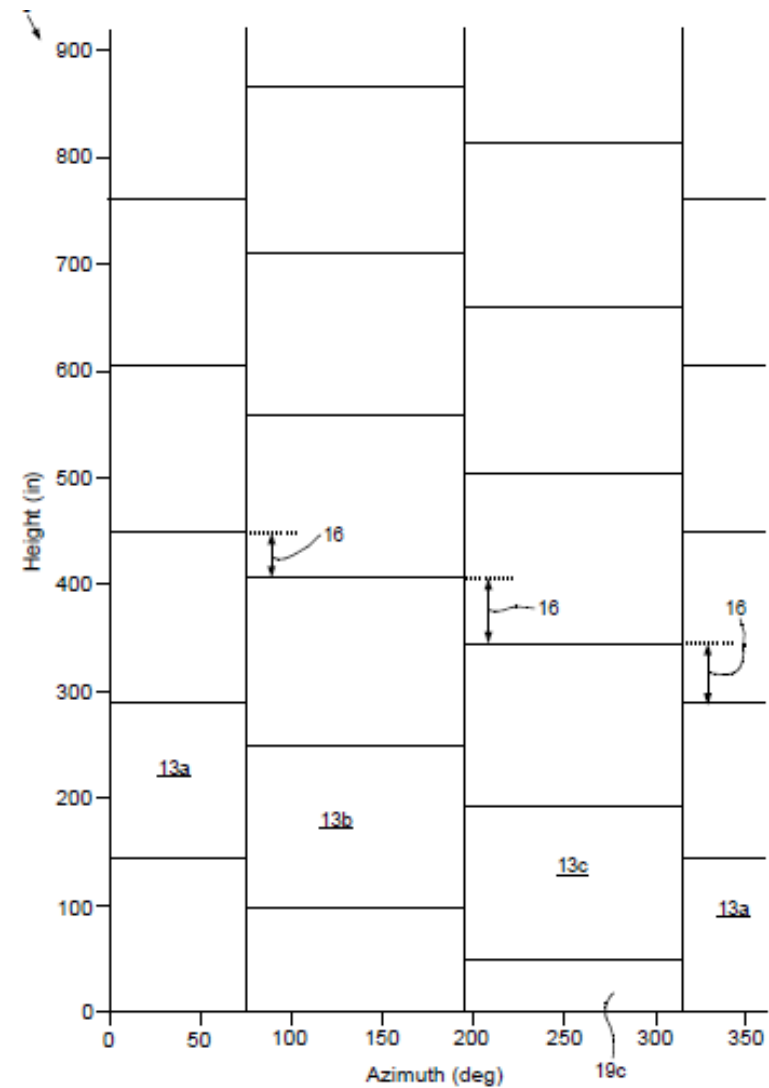
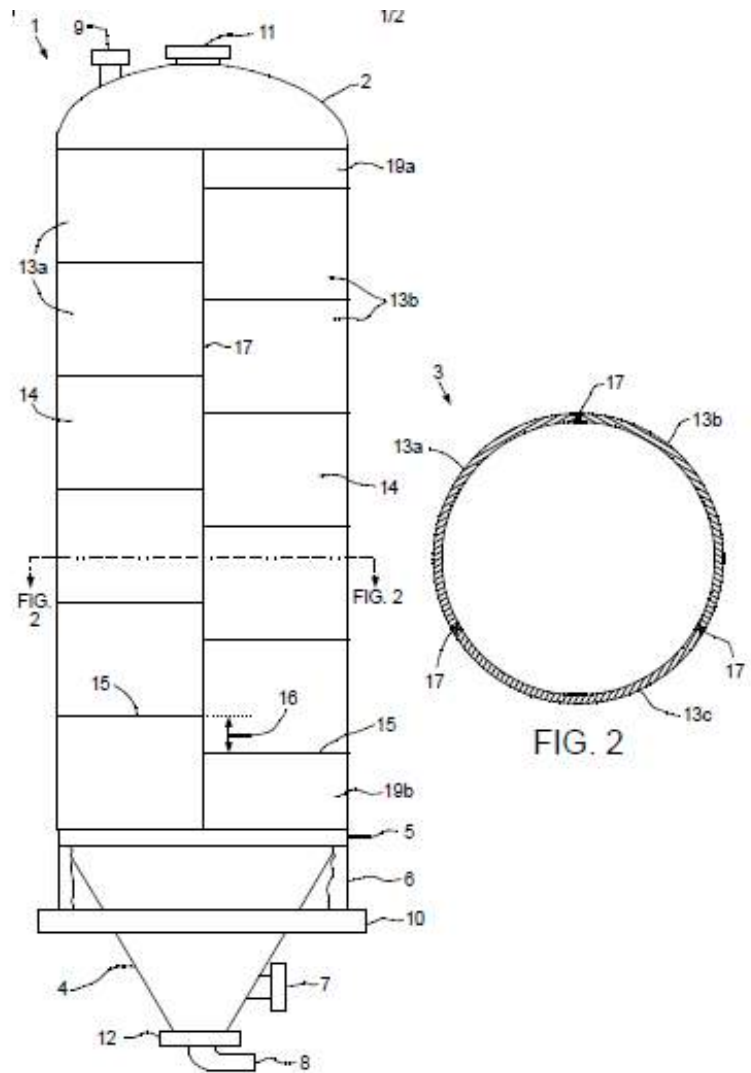

Status

- Not aware of any precedents
- No pending implementation

Summary

Three issued and pending HES patents in last two years aimed at mitigating or minimizing classic coke drum failures:

- Tongue-and-Groove skirt attachment
 - Being implemented
- Clearance-Restraint skirt anchors
 - Being implemented
- Staggered-Seam shell design